

! WARNING

**THIS SHIFTER IS
FOR RACING USE ONLY
NOT FOR STREET USE!**

READ ALL OF THIS INFORMATION CAREFULLY

1. All adjustments must be made with shifter and transmission in *Neutral (N)*.
2. Adjustments are critical and must be precise.
3. Do not mix components (all parts including cable must be Hurst components provided with kit).
4. If a shifter is removed and reinstalled, adjustments must be checked, and re-adjusted.
5. Always check cable for freedom of motion before connecting at shifter and transmission arm.
6. Routing of cable should avoid sharp bends—(permanent damage of cable will result).

FAILURE TO COMPLY WITH ANY OF THE ABOVE MAY RESULT IN MALFUNCTION OF SHIFTER OPERATION. DAMAGE TO CABLE DUE TO SHARP BENDING OR KINKING IS NOT COVERED BY WARRANTY.



QUARTER STICK

INSTALLATION INSTRUCTIONS

316 0006 316 0007 316 0009 316 0010

These instructions detail the installation of Hurst Quarter Stick shifters for the control of GM turbo hydramatic, Ford C4 and C6, and Chrysler 904 and 927 transmissions. The shifter can be mounted directly to the floor of the vehicle under four sheet metal screws supplied, or can be fixed to be quickly attached and released by use of a Quick release plate and quick-release pins.

Four spacers (Pt. 2280113) are provided with the aluminum enclosure package (Pt. 1300038). These spacers are to be fastened to the inside surface of the aluminum cover with epoxy adhesive. See section view on page 4.

Specifications for making a "Quick release plate" are found on page 4 of this sheet. This plate is to be made from 1/8" thick aluminum or steel, and allows shifter to be installed and

removed by simply inserting and withdrawing quick release pins (not included). The aluminum cover and the quick release pins are available from Hurst. Order Pt. 1300038.

A Quick Release plate is also available from Hurst Performance dealer outlets. Ask for Part No. 1950209

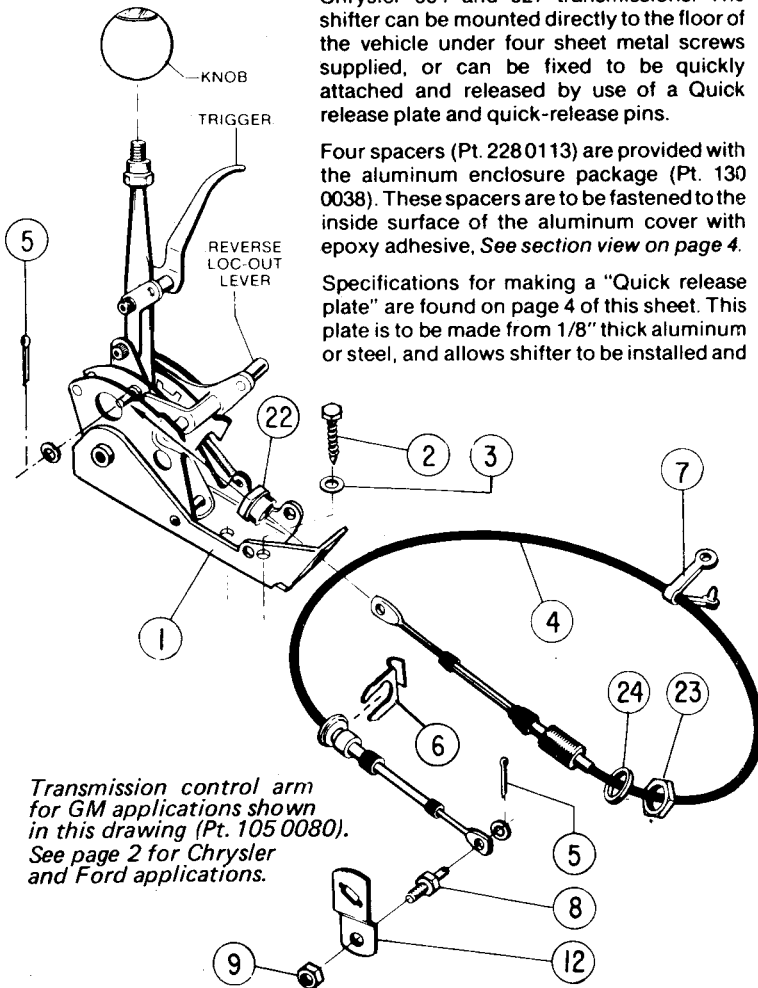

Transmission control arm for GM applications shown in this drawing (Pt. 1050080). See page 2 for Chrysler and Ford applications.

CONTENTS OF KIT

- | | |
|---|----------------------------|
| 1. SHIFTER ASSEMBLY | GM—PT. 316 0007 |
| | FORD/CHRYSLER—PT. 316 0010 |
| 2. 1/4" x 1" SELF-TAPPING SHEET METAL SCREW | PT. 272 5699 (4) |
| 3. 1/4" FLATWASHER | PT. 97000818 (4) |
| 4. CABLE | Ford/Chrysler—PT. 120 5721 |
| 4A. CABLE | GM—PT. 120 0025 |
| 5. COTTER PIN | PT. 190 3539 (2) |
| 6. CABLE ATTACHMENT CLIP | PT. 127 5702 (2) |
| 7. CABLE SUPPORT CLAMP | PT. 126 0013 |
| 8. CABLE ATTACHMENT PIN | PT. 189 0011 |
| 9. 3/8-16 SELF-LOCKING HEX-NUT | PT. 179 5959 |
- Refer to drawings of Cable Termination at Transmissions on Page 2 for further Parts Identification.
- | | |
|---|------------------|
| GM TURBO-HYDRAMATIC INSTALLATIONS—GM 350, 400 & 200 METRIC | |
| 10. BRACKET—TRANS.—CABLE MOUNTING | PT. 117 5711 |
| 11. 5/16—18 x 3/4 SOCKET HEAD CAP SCREW | PT. 215 0018 |
| 12. ARM—TRANSMISSION CONTROL SHAFT | PT. 105 0080 |
| CHRYSLER INSTALLATIONS—TORQUE-FLITE 904 & 727 | |
| 13. BRACKET—TRANS.—CABLE MOUNTING | PT. 117 0094 |
| 14. ARM—TRANSMISSION CONTROL SHAFT | PT. 105 5984 |
| 15. 5/16" FLATWASHER | PT. 96000559 (4) |
| FORD INSTALLATIONS—C4 & C6 | |
| 16. BRACKET—TRANS.—CABLE MOUNTING—C4 | PT. 117 0037 |
| 17. BRACKET—TRANS.—CABLE MOUNTING—C6 | PT. 117 0038 |
| 18. ARM—TRANSMISSION CONTROL SHAFT | PT. 105 0062 |
| CHRYSLER AND FORD INSTALLATIONS | |
| 19. 1/4-28 x 1-1/2 HEX-HEAD CAPSCREW | PT. 215 4052 |
| 20. 1/4" SPLIT LOCKWASHER | PT. 97090082 |
| 21. 1/4-28 SQUARE NUT | PT. 179 0056 |
| 22. BEZEL NUT | PT. 179 0089 |
| 23. HEX-NUT | PT. 179 0090 |
| 24. FLATWASHER | PT. 267 0097 |

BAGGED HARDWARE PACKAGES—PT. 154 0175 (GM) & PT. 154 0179 (FORD/CHRYSLER)—ALSO PT. 154 0184 (CABLE)

CABLE CONNECTIONS AT TRANSMISSION CONTROL SHAFT

CHRYSLER 904 & 727 TORQUEFLITE

NOTE:
CABLE APPROACHES
TRANSMISSION
FROM FRONT
OF VEHICLE

PLACE 2 FLATWASHERS
BETWEEN EACH END OF
BRACKET AND PAN AS
SHOWN. USE LONGER
BOLTS IF NECESSARY.
(BOLTS ARE NOT SUPPLIED)

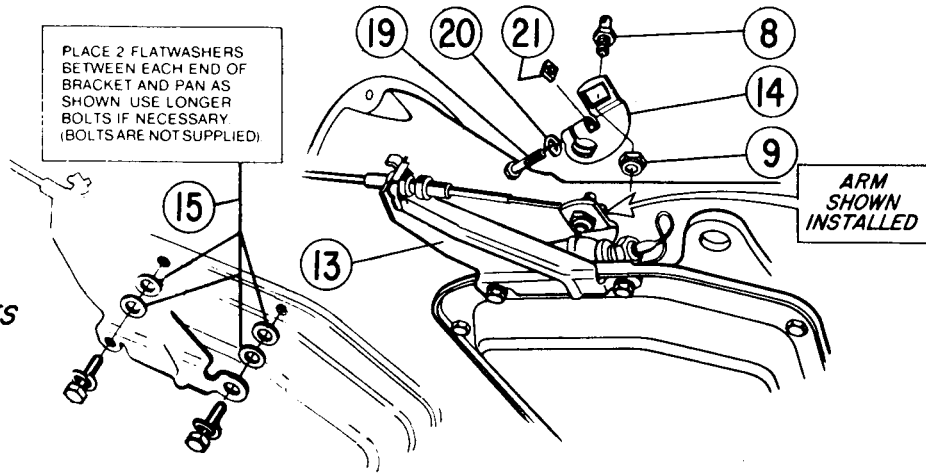

GM INSTALLATIONS

All GM installations use this
bracket (Pt. 117 5711). Refer to
drawings below for method of
fastening

TRANSMISSION
CABLE BRACKET
PT. 117 5711

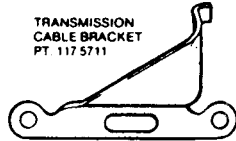

400 TURBO-HYDRAMATIC

USE STOCK BOLTS TO FASTEN END HOLES OF
BRACKET TO TRANSMISSION

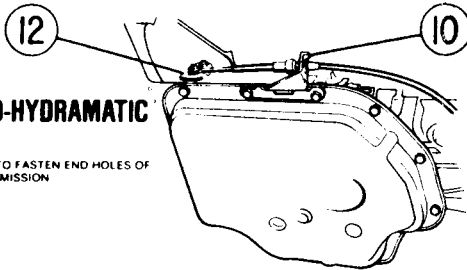

350 TURBO-HYDRAMATIC

INSTALL BRACKET WITH 5-16-18 x 3/4 SOCKET
HEAD CAP SCREW LOCATED AT REAR END OF
SLOT (BRACKET FORWARD AS FAR AS
POSSIBLE)

350 TURBO-HYDRAMATIC AND 200 METRIC
TURBO-HYDRAMATIC

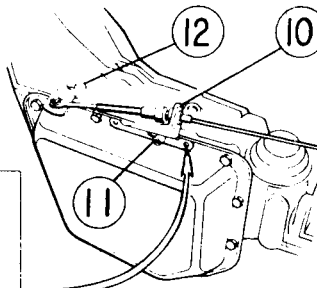

After installation has been completed, drill a
21/64 diameter hole through transmission
case at rear mounting hole in bracket (use
hole in bracket as drill guide). Fasten the rear
end of bracket to transmission with a suitable
5/16" diameter bolt, lockwasher, and nut. These
items are not supplied with this kit. The
lockwasher and nut are installed on the top
side of the transmission case. This hardware is
not shown in these drawings.

THIS OPERATION
IS OPTIONAL

200 TURBO-HYDRAMATIC

INSTALL BRACKET WITH 5-16-18 x 3/4 SOCKET
HEAD CAP SCREW LOCATE SCREW AT MIDDLE
OF SLOT. THE LOCATION CAN BE ADJUSTED
WHEN YOU PERFORM 'NEUTRAL ALIGNMENT'
OPERATION DESCRIBED IN TEXT

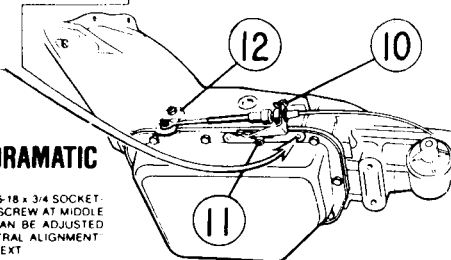

FORD INSTALLATIONS

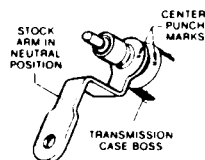

ROTATE STOCK ARM TO "N"
(NEUTRAL). USE CENTER
PUNCH TO MAKE MARK ON
ARM AND CORRESPONDING
MARK ON TRANSMISSION
CASE BOSS.

REMOVAL OF STOCK FORD ARM— INSTALLATION OF HURST ARM

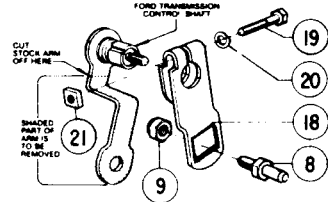

CUT SHADED PART OF STOCK ARM OFF. INSTALL
HURST ARM ON SHAFT (CABLE PIN LOOSELY
INSTALLED IN ARM). DO NOT TIGHTEN CLAMP BOLT.
MOVE SHIFTER STICK TO "N" (NEUTRAL). PLACE
CABLE END ON PIN. ADJUST ARM TO POSITION
WHERE PIN IS AT CENTER OF SLOT. TIGHTEN CLAMP
BOLT. TIGHTEN NUT ON PIN.

FORD C-4

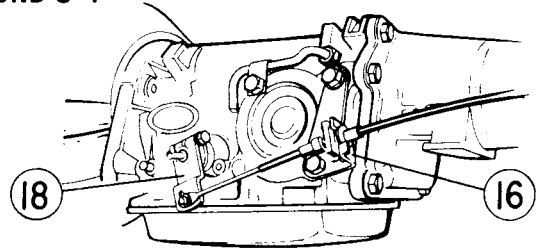

FORD C-6

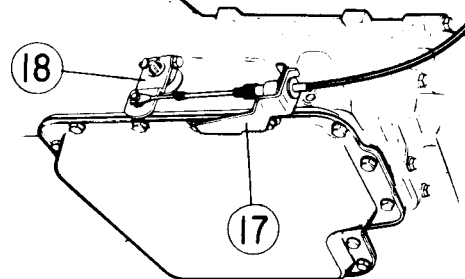

Carefully direct threaded end of cable through shifter frame toward cable stud as shown in exploded view. Secure threaded portion of cable housing to shifter frame as shown using bezel nut (Item #22), hex nut (Item #23), and flatwasher (Item #24). Center thread so that an equal amount is visible on each end after nuts are finger tightened. * For Ford/Chrysler 316 0009, slide end of cable through hole in shifter housing and place clip (item #6) on cable to secure its position.

Temporarily slide end of cable on stud to insure proper routing through shifter. Refer to detail drawing. Shift to neutral, then slide cable off of pin.

Remove stock transmission arm. Assemble the cable pin in the Hurst arm with hex nut as shown. Install the arm on transmission control shaft. Install cable bracket on transmission. Refer to directions with the illustration

of your installation. Carefully route the cable toward the transmission cable mounting bracket and fasten in place with the cable attachment clip (Item #6). Push clip in until it is seated against ferrule on cable and front face of transmission cable mounting bracket. (CAUTION—AVOID SHARP BENDING OF CABLE. CABLE WILL BE PERMANENTLY DAMAGED BY ANY SHARP BENDING.)

Locate cable hanger (Item #7) to apply support where it is most needed. Drill a 1/4 diameter hole through floor for cable hanger. Fold clamp around cable, push split end through hole in floor. Push pointed end through split end. Apply force until joint snaps together.

Rotate transmission arm to neutral (see illustration of shifter and transmission arm) and secure moveable end of cable to pin with flatwasher and cotter pin.

At shifter note position of moveable spade end of cable relative to cable stud. Shifter should be in neutral. Using the retaining nuts at threaded portion of cable, adjust the cable until spade end will freely enter on to cable stud. Shift through each gear position (up & down) and check for free entry of cable end on stud in each gear position—re-adjust if necessary to insure proper function. When satisfied with adjustment, tighten retaining nuts on threaded portion of cable without disturbing previous adjustment. Install cotter pin on stud and secure.

NOTE: If adjustment feature of cable is installed at transmission end, the same procedure for adjustment must be used, while a helper is shifting the Quarter Stick.

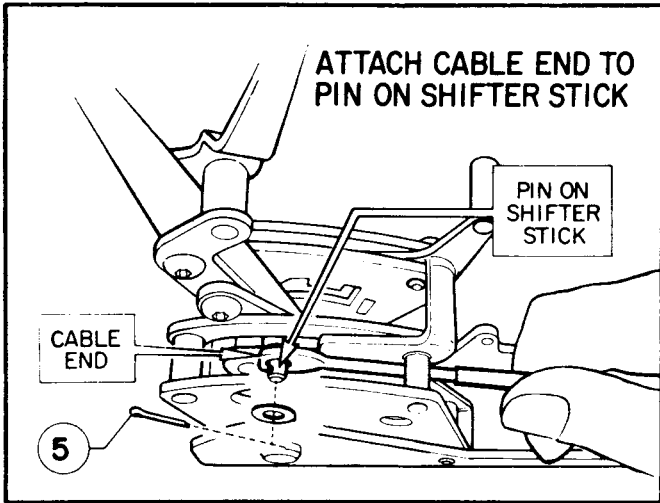

ALIGNMENT PROCEDURE

1. Position shifter stick at "N" (Neutral).
2. Position transmission arm at "N" (Neutral).
3. Adjust cable as directed in text which appears in column directly below on this page.
4. Fasten cable end on pin with flatwasher and cotter pin.

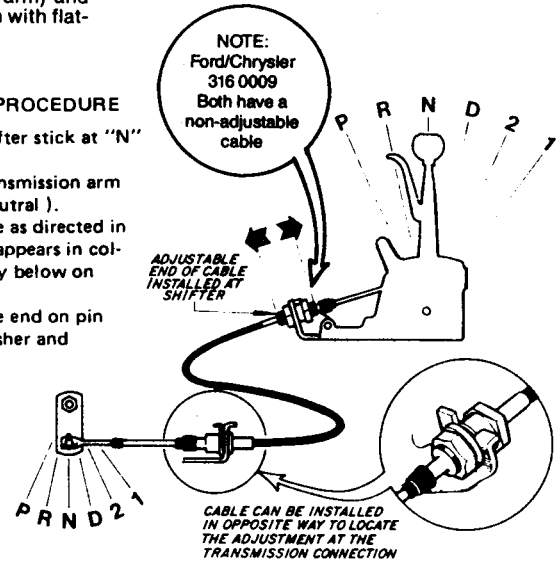

SHIFTING PATTERN CHANGES

Lockplate opening shown

1 FIRST GEAR



PULL STICK ALL THE WAY BACK

4

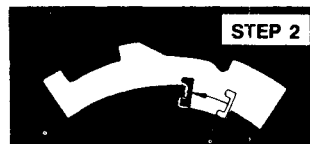

WHILE HOLDING TRIGGER PUSH STICK FORWARD

7 REVERSE

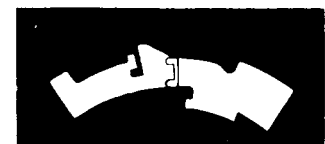

PUSH REVERSE LOC/OUT LEVER DOWN, AND PUSH STICK FORWARD

2 SECOND GEAR



PUSH STICK FORWARD

5



RELEASE TRIGGER AND RELAX STICK

8 PARK

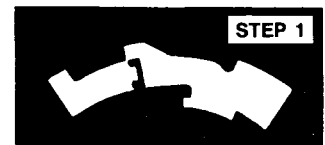

PULL TRIGGER AND HOLD

3 THIRD GEAR



PULL TRIGGER AND HOLD

6 NEUTRAL



PUSH STICK FORWARD TO NEUTRAL

9

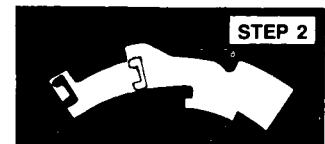

PUSH STICK FORWARD ALL THE WAY AND RELEASE TRIGGER.

QUICK-RELEASE FLOOR PLATES

OPTIONAL ALUMINUM COVER (PT. 130 0038)

OPTIONAL

IF SHIFTER IS FASTENED DIRECTLY TO FLOOR (QUICK-RELEASE PLATE IS NOT USED)—REFER TO SECTIONED DRAWING BELOW.

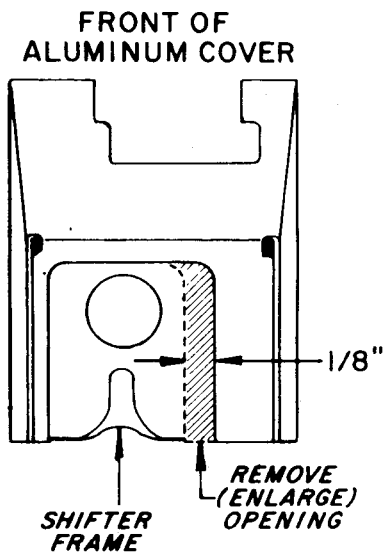
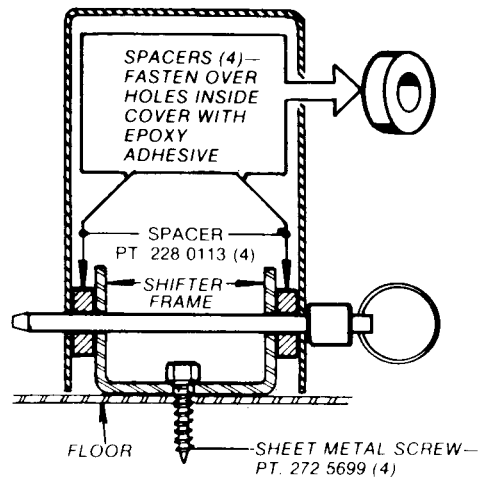
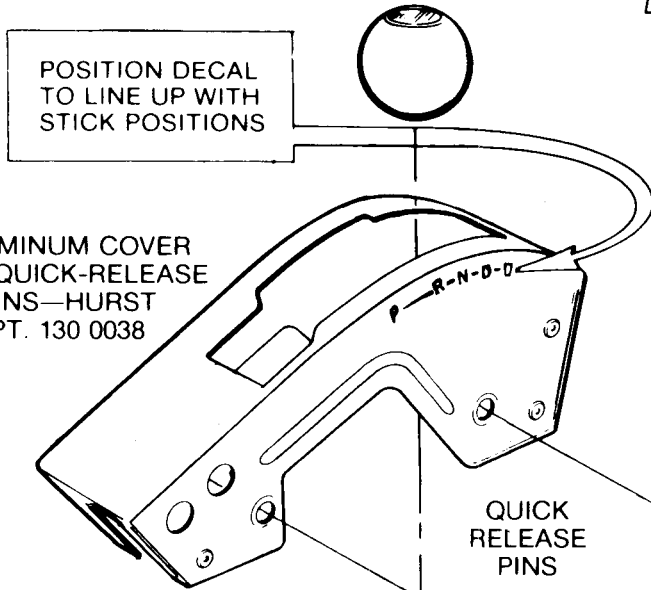

IF YOU WISH TO FABRICATE YOUR OWN QUICK-RELEASE PLATE, USE THESE DIMENSIONS

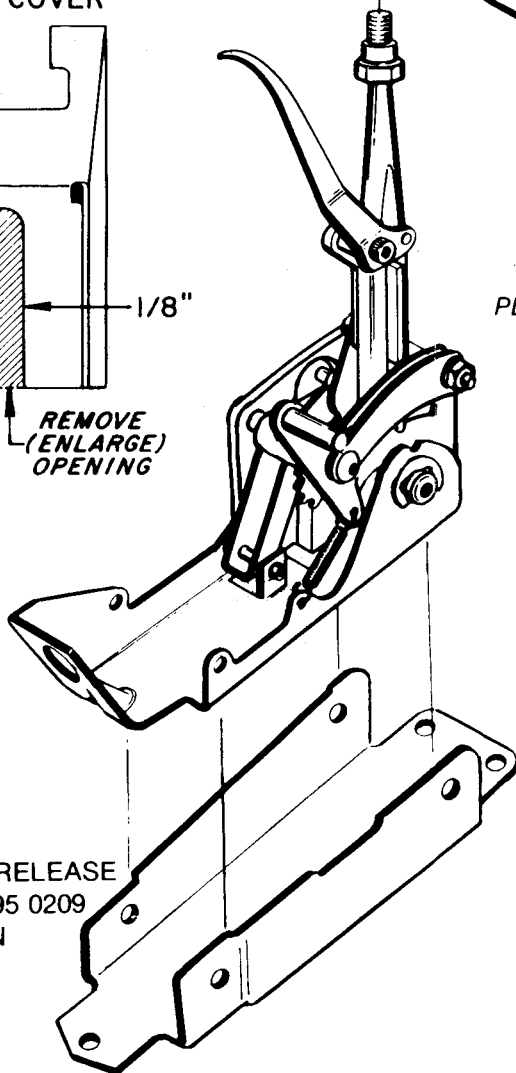
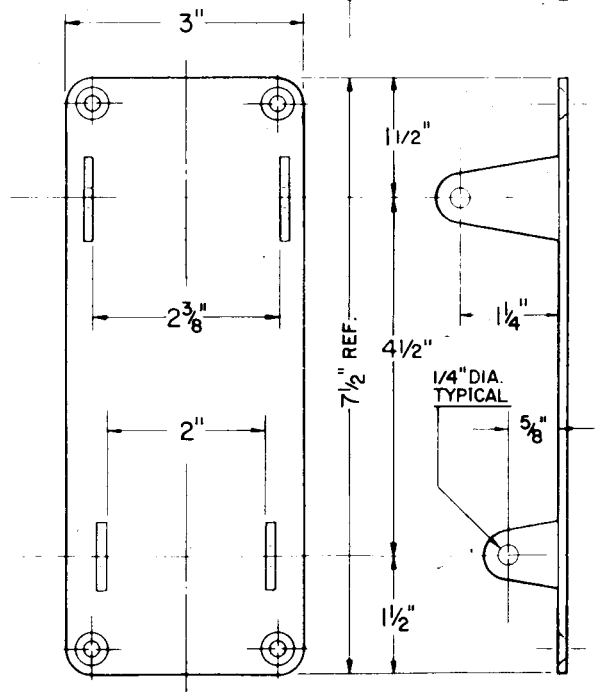
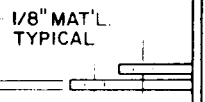

HURST QUICK-RELEASE PLATE, PT. 195 0209 SHOWN